

# OSRAM ECOPACK®-FH

## OSRAM ECOPACK®-FH DIM

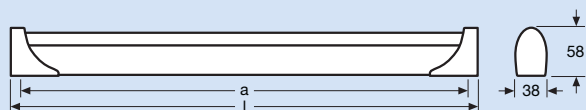

### OSRAM ECOPACK®-FH

Type	Product no. WHITE	Prod. ref.	SP	l [mm]	a [mm]
14 W	4050300513249	72601	4	584	538
21 W	4050300513263	72602	4	884	838
28 W	4050300513287	72603	4	1184	1138
35 W	4050300513300	72604	4	1484	1438

### OSRAM ECOPACK®-FH DIM

Type	Product no. WHITE	Prod. ref.	SP	l [mm]	a [mm]
14 W	4050300659213	72611	4	584	538
21 W	4050300659237	72612	4	884	838
28 W	4050300659251	72613	4	1184	1138
35 W	4050300659275	72614	4	1484	1438

### ACCESSORIES: Pendant kit

Type	Product no. SILVER	Prod. ref.	SP
Pendant kit	4050300792200	72097	4

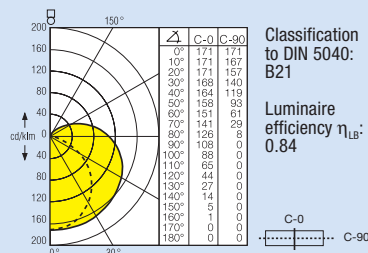

Classification to DIN 5040: B21

Luminaire efficiency  $\eta_{LB}$ : 0.84

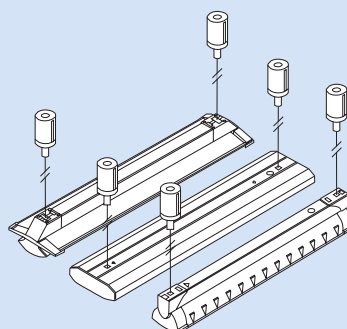

## Description and features

OSRAM ECOPACK®-FH extremely low power consumption: It provides the same light using less power than comparable batten luminaires of the same length with 26 mm fluorescent lamps.

- Compact electronic batten luminaires for fixed connection
- With innovative FH® fluorescent lamp
- With QUICKTRONIC® QT-FH or QT-FH DIM electronic control gear
- Long lamp life thanks to cut-off technology
- With prismatic lamp cover for uniform light distribution
- OSRAM ECOPACK®-FH DIM:
  - dimmable from 100 % to 1 %
  - controlled by 1...10V DC control signals, suitable for daylight-dependent lighting control using OSRAM light sensors

## Technical data and equipment

- Equipped with light colour 830 FH® lamp
- Mains voltage: 230-240 V/0, 50-60 Hz
- IP40
- Colour: white

## Accessories

- Daylight sensors for constant lighting control for OSRAM ECOPACK®-FH DIM (see page 20)
- Pendant kit (for a description see page 23)

