

# HALONESTRA® HALONEA®

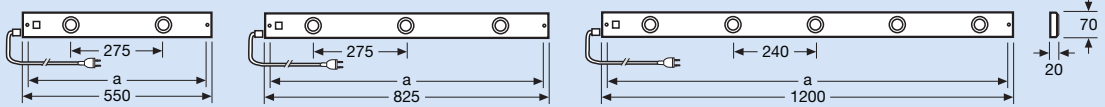

## HALONESTRA®

Type	Product no. WHITE	Prod. ref.	SP	a [mm]
2 x 20 W	4050300486338	41132	4	521
3 x 20 W	4050300486352	41133	4	796
5 x 10 W	4050300486376	41134	4	1171

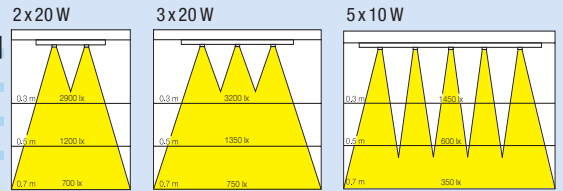

### Accessories: Socket element and socket/switch element (for HALONESTRA®, LUMINESTRA® EL)

Type	Product no. WHITE	Prod. ref.	SP	a [mm]
Socket element, 2-way	4050300486390	41132-50	4	160
Socket/switch element	4050300486413	41132-56	4	160

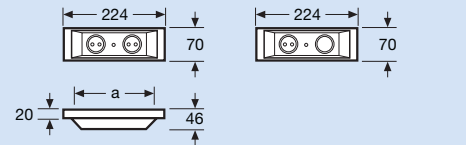

## HALONEA®

Type	Product no. WHITE	Prod. ref.	SP	l [mm]	a [mm]
2 x 10 W	4050300784519	41135	4	328	246
3 x 10 W	4050300784540	41136	4	504	422

### Accessories: Socket element and socket/switch element (for HALONEA®, LUMILINE® EL)

Type	Product no. WHITE	Prod. ref.	SP	a [mm]
Double socket	4050300772219	41137	4	160
Socket/switch	4050300807263	41138	4	160

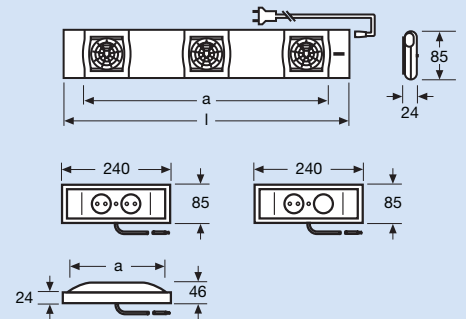

### Accessories: Connecting cable (for HALONESTRA®, HALONEA®)

Type	Product no. WHITE	Prod. ref.	SP
100 mm	4050300125602	74101-52	10
600 mm	4050300125626	74101-53	10
1000 mm	4050300125640	74101-54	10

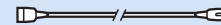

## Description and features

At only 20 mm high, the super-slim HALONESTRA® furniture luminaires provide a variety of lighting solutions with brilliant halogen light. HALONEA® adds modern design to the family of furniture luminaires.

- Very low-profile halogen batten luminaires with electronic transformers
- Ready to install with rocker switch, 2 m of cable and plug
- With two or three halogen lamps (HALONESTRA® up to five lamps) and reflectors integrated directly in the luminaire
- Through-wired to create strip lighting with plug adapter or connecting cable supplied (accessories)
- HALONESTRA®/HALONEA® dimmable with trailing-edge phase dimmer

## Technical data and equipment

### HALONESTRA®

- Equipped with pin-base lamp HALOSTAR® 64425 (2 x 20 W, 3 x 20 W) or HALOSTAR® 64415 (5 x 10 W)
- Mains voltage: 230-240 V/50-60 Hz
- IP20
- Colour: white

### HALONEA®

- Equipped with HALOSTAR® 10 W/12 V lamp
- Mains voltage: 230 V/50-60 Hz
- IP20
- Colour: white

## Accessories

- Connecting cable 100, 600, 1000 mm
- Socket element, socket/switch element (for HALONESTRA®/HALONEA®)



### Socket element, socket/switch element

The socket element is designed as a power feed unit for strip lighting comprising HALONESTRA®/LUMINESTRA® EL or HALONEA®/LUMILINE® EL luminaires. The entire strip lighting system can be switched on and off at the switch. Protection class I. Colour: white



HALONESTRA®/LUMINESTRA® EL or HALONEA®/LUMILINE® EL can be connected to form strip lighting using the plug adapter supplied. Using the plug adapter up to 8 HALONESTRA®/LUMINESTRA® EL units can be connected to form strip lighting. (For a description of LUMINESTRA® EL see page 34)